

FKAR series



■ Specifications

Model		FKAR-17K	FKAR-27K
Fluid		Air	Air
Pressure resistance		2.5 MPa	3.5 MPa
Maximum inlet pressure		2.0 MPa	3.0 MPa
Regulating range		0.1 Mpa ~ 1.7Mpa	0.1 Mpa ~ 2.7Mpa
Ambient and fluid temperature		5~90℃	5~90℃
Mechanism		Relief mechanism	Relief mechanism
Weight (g)	FKAR201	260	270
	FKAR301	654	660
	FKAR401	935	950

■ How to order

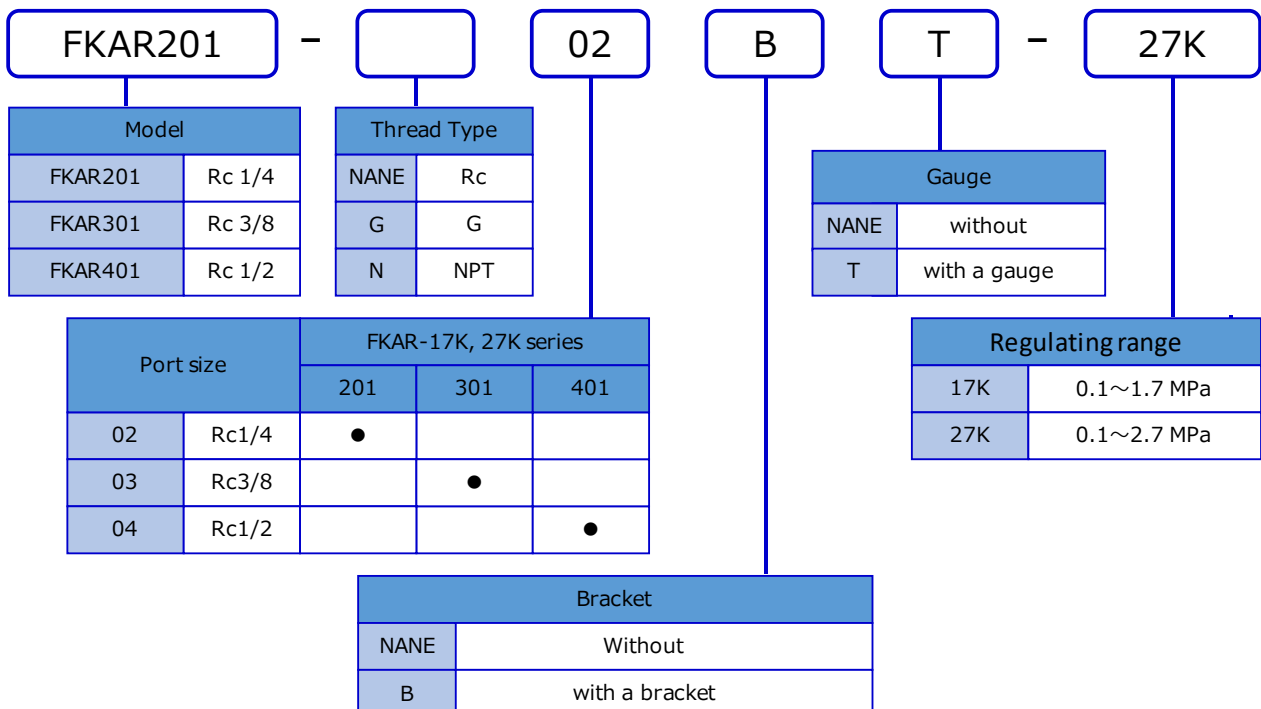

■ Dimensions

<FKAR201>

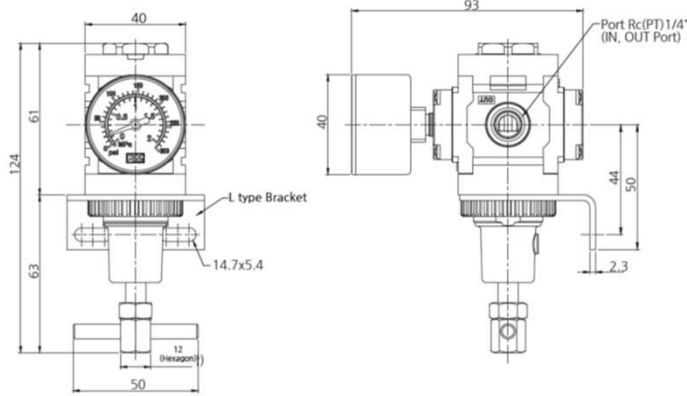
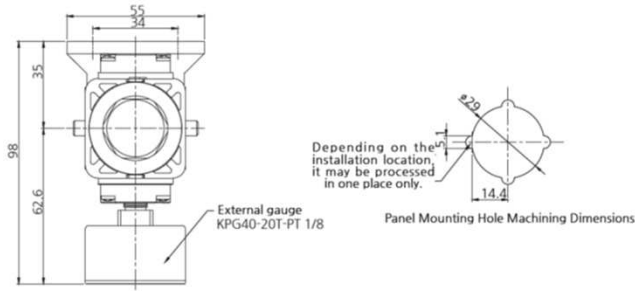

<FKAR401>

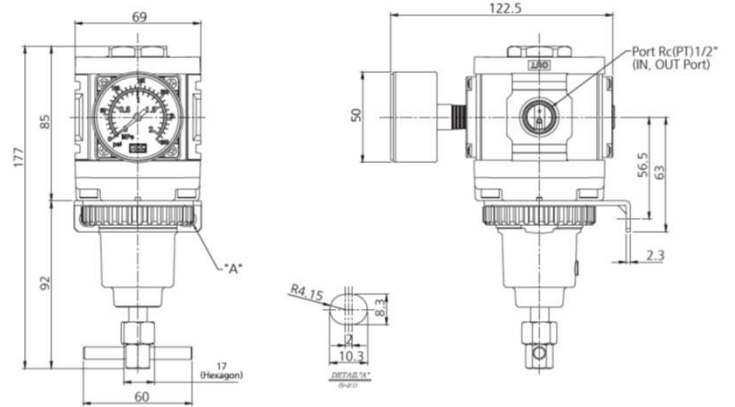
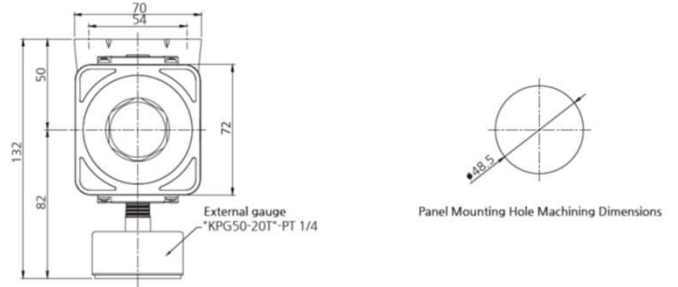

<FKAR301>

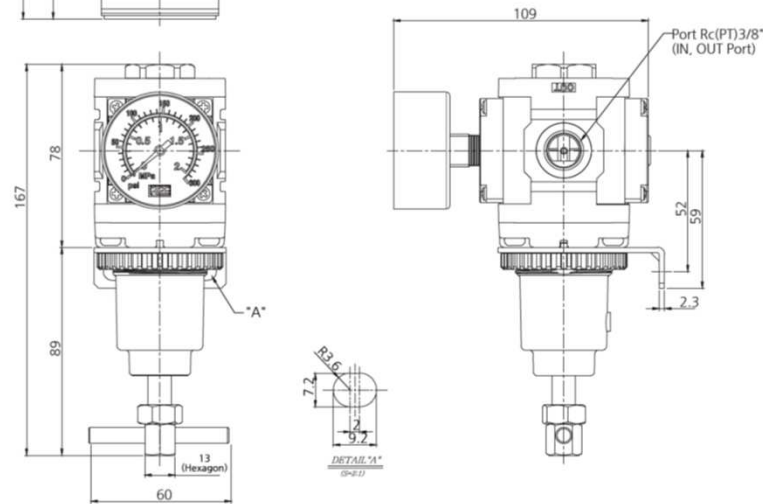
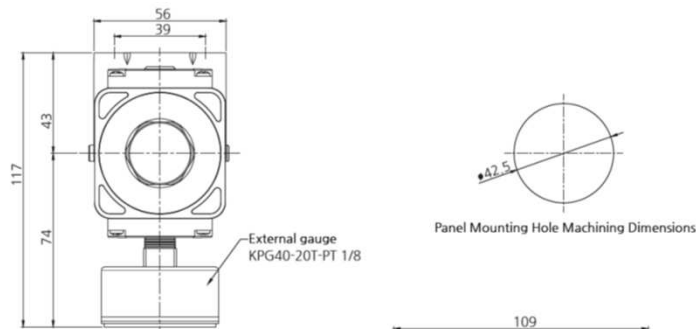

FUJIKURA COMPOSITES Inc.
 TOC Ariake East Tower 10F, 3-5-7 Ariake, Koto-ku, Tokyo, Japan 1350063
 TEL.03-3527-8573 FAX.+81-3-3527-8390
 URL: <https://www.fujikura-control.com/>
 e-mail: seigy.toiawase.en@fc.fujikura.co.jp